



Tape Head Survey & Upgrade Data Sheet

CONTACT INFORMATION								
STA MANAGER						DATE		
DISTRIBUTOR CONTACT INFORMATION				COMPANY CONTACT INFORMATION				
DISTRIBUTOR				COMPANY				
LOCATION				LOCATION				
SALESPERSON				CONTACT				
PHONE				PHONE				
FAX				FAX				
EMAIL				EMAIL				
PRESENT SUPPLIER INFORMATION								
DISTRIBUTOR			TAPE MANUFACTURER		ROLL SIZE		ANNUAL VOLUME	
STANDARD PRE-ENGINEERED INSTALLATION ADAPTERS								
MAILLIS / 3M			IPG INTERPACK		ITW SIGNODE		DEKKA BELCOR	
1AF	16RF	77RLM	USA		UCS		130	
2A	22A	100	RSA		UCF		150	
8A	22ALM	120AF	RSA		RCS		185	
12A	23A	200	UA				250	
12AB	77A	700					252	
12AF	77ALM	800					505	
12RF	77R	800AF					507	
PLANT EQUIPMENT SURVEY & TAPE HEAD UPGRADE INFORMATION								
MAKE AND MODEL OF		UPGRADING		# OF MACHINES	TYPE OF EQUIPMENT			KIT NUMBER
MACHINE	TAPE HEAD	TOP	BOTTOM		SEMI-AUTOMATIC	AUTOMATIC	CASE ERECTOR	
TECHNICAL REVIEW BY:						DATE:		
COMMENTS: _____								



Tape Head Survey & Upgrade Data Sheet

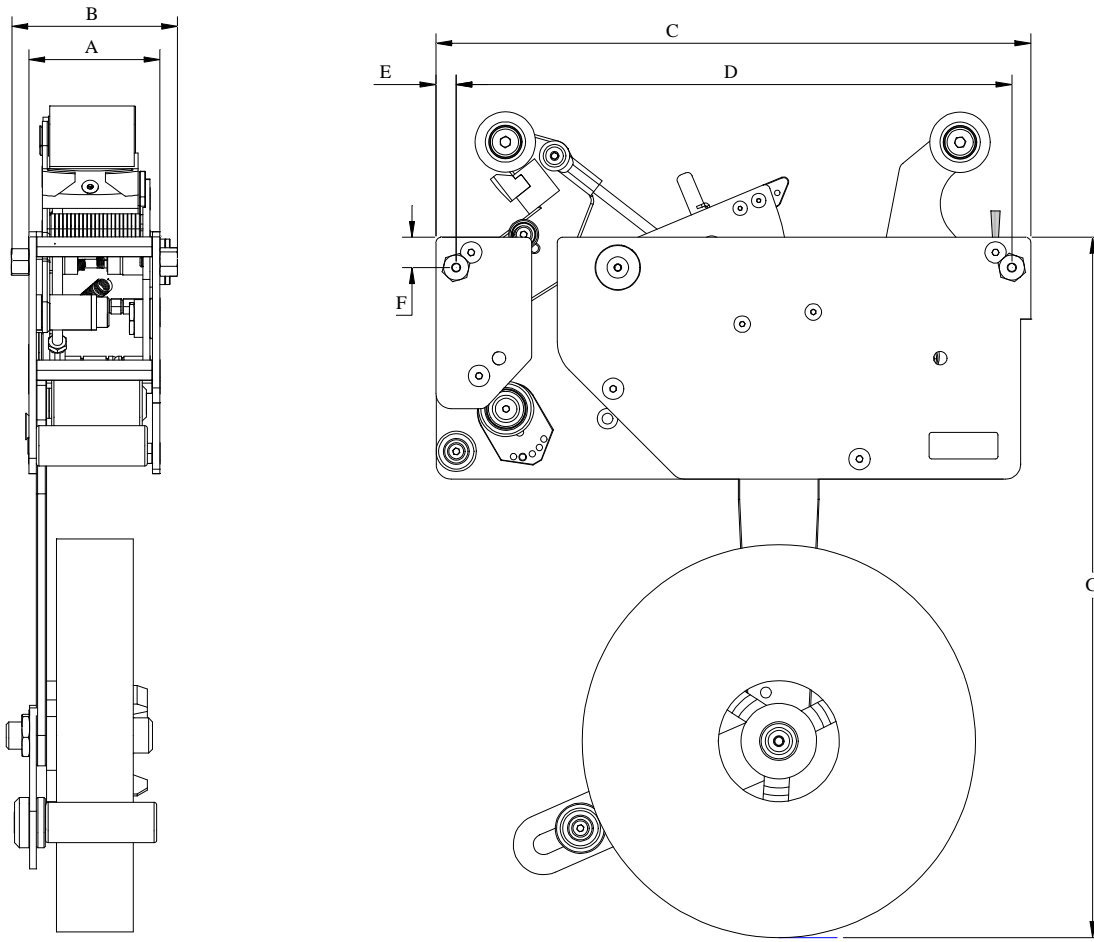

6mm X 6	6mm X 1/4 Dia.				
6mm X 12	6mm X 3/8 Dia.	3/8-24 to 6mm X 1		6mm X 1 X .150	
1/4-20 X 3/4	6mm X 1/2 Dia.	3/8-24 to 1/4-20	6mm X 1 to 6mm X 1	6mm X 1 X .650	Special Brackets

For reference purposes, please provide a digital photograph of existing machine and tape head.

Measurement of Existing Installation	Measurement
A Width of Tape Head	
B Width Including Installation Adapters	
C Length of Tape Head	
D Center Distance of Installation Adapters	
E Centerline of Adapters to Front Face of Tape Head	
F Centerline of Adapters to Top Face of Tape Head	
G Top Fact of Tape Head Including 914M Tape Roll	

Processing Specifications			
Case Processing Speed	FPM:		
Tape Sensors	Low Tape	No Tape	
Upgrading	Top	Bottom	
Wash Down Application	Yes	No	
Installation Position	Right Hand	Left Hand	
Tape Roll External	Yes	No	
Case Wear Plate	Yes	No	