

## Uniform Fully Automatic, Top and Bottom Case Sealer

# STA-F47

S E R I E S

- Engineered for 24 hour operation
- Unique four flap closing system
- Simple, reliable side drive belt system
- 90 feet per minute belt speed
- 2" or 3" taping
- Six tape head variations
- Fast, easy set-up and adjustments
- Safety guards standard
- Motor overload protection
- Heavy duty transmission system
- Heavy duty frame
- Heavy duty casters are standard

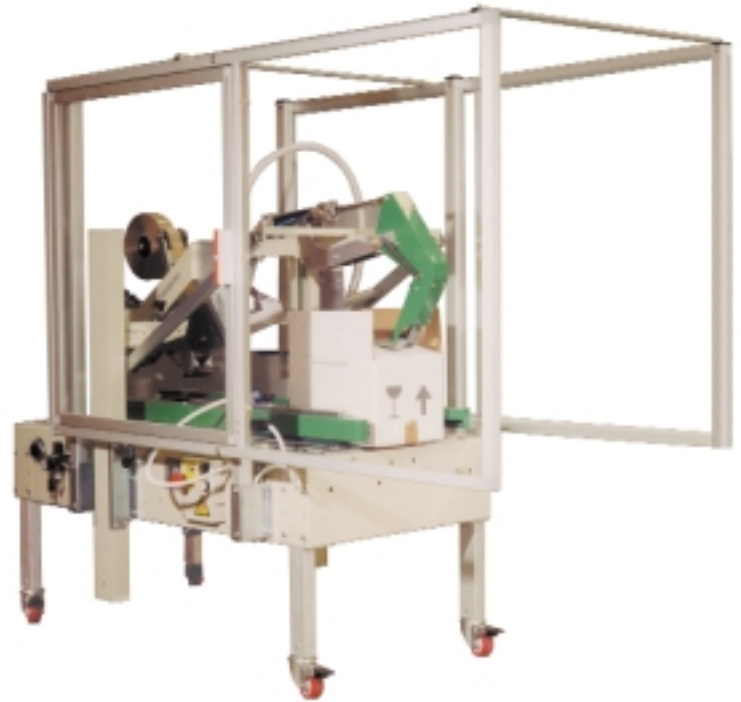

## APPLICATION

The STA-F47 Series is a precision engineered uniform fully automatic, top and bottom case sealer designed for processing uniform cases. **No operator** is required because the top flaps are automatically folded with the unique four flaps closing system, and fed into the machine for top and bottom taping.

Additionally, a variation of six tape heads accommodate a wide range of packaging applications. However, for all of its sophistication, the STA-F47 Series is one of the easiest, fastest case sealers to set up or adjust, saving you both labor and downtime costs.

## EXCLUSIVE STA TAPE HEAD

The patented STA taping head design is uniquely engineered to maintain consistent pressure to the tape to ensure the most secure, reliable seal possible. Our new line of interchangeable pressure sensitive taping heads are offered in a variety of tab lengths and tape widths to fit your application.

For the best results, rely on STA Proven Performance acrylic tapes, for use with your high-throughput automatic sealing machines. Together, you have the most reliable single source tape sealing system.



# STA-F47

S E R I E S

Uniform Fully Automatic,  
Top and Bottom Case Sealer

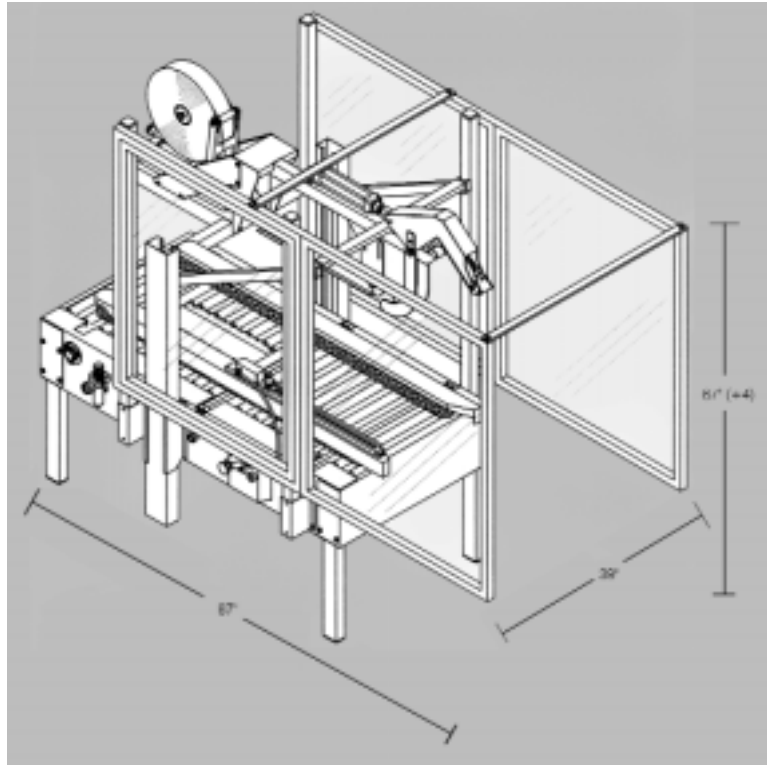

## TAPE

- SUPREME
- EASY RELEASE™
- NATURAL RUBBER
- PRINTED
- COLORS
- RETAIL ROLL
- LABEL PROTECTION
- STATIONERY
- UPVC
- MASKING
- STRAPPING
- FILAMENT
- WATER ACTIVATED REINFORCED AND GUMMED PAPER

## DISPENSERS

- HAND DISPENSERS
- NOISE REDUCING DISPENSERS
- BENCH DISPENSERS

## MACHINES

- UNIFORM SEMI-AUTOMATIC CASE SEALERS
- UNIFORM AUTOMATIC CASE SEALERS
- RANDOM SEMI-AUTOMATIC CASE SEALERS
- RANDOM AUTOMATIC CASE SEALERS
- PACKING STATIONS
- CASE ERECTORS
- INTERCHANGEABLE TAPE HEADS

## ACCESSORIES

- PACKING TABLES & STATIONS
- CASTERS
- THREE FLAPS CLOSERS
- BOX BLOCKING SYSTEM

## SPECIFICATIONS

Model Number	Tape Width	Tab Length	Length Min. - Max.*	Width Min. - Max.*	Height Min. - Max.*
STAF47	2"	2"	6.00" - 27.50"	4.00" - 20.00"	4.00" - 20.00" (+4)
STAF4723	2"	3"	6.00" - 27.50"	4.00" - 20.00"	4.69" - 20.00" (+4)
STAF4733	3"	3"	6.00" - 27.50"	4.69" - 20.00"	4.69" - 20.00" (+4)
STAF4732	3"	2"	6.00" - 27.50"	4.69" - 20.00"	4.00" - 20.00" (+4)

\*Recommended carton specifications may vary

<b>Power Requirements:</b>	110V / 60Hz / 1PH
<b>Tape Width:</b>	2-in. standard, 3-in. available
<b>Maximum Case Weight:</b>	95 lbs.
<b>Air Requirement:</b>	PSI: 80-100 lbs., CFM: 1-3, dry air, 3/8" supply line
<b>Machine Dimensions:</b>	87" x 39" x 68" (+4) (LxWxH)
<b>Shipping Dimensions:</b>	71" x 41" x 62" (LxWxH)
<b>Machine Weight:</b>	410 lbs.
<b>Shipping Weight:</b>	507 lbs.

Authorized STA Packaging Tapes Distributor:

Specifications are subject to change without notice. Printed in the U.S.A. All trademarks and registered trademarks are property of Sekisui TA Industries, Inc.